



Chrysler, Dodge, Jeep **Multikit** (with factory NAV) 2004-2009

KIT FEATURES

- ISO DIN radio provision with pocket
- ISO DDIN radio provision
- Designed for vehicles with factory navigation radios

KIT COMPONENTS

- A) Radio housing
- B) Radio brackets
- C) Pocket
- D) (4) #8 x 3/8" Phillips screws

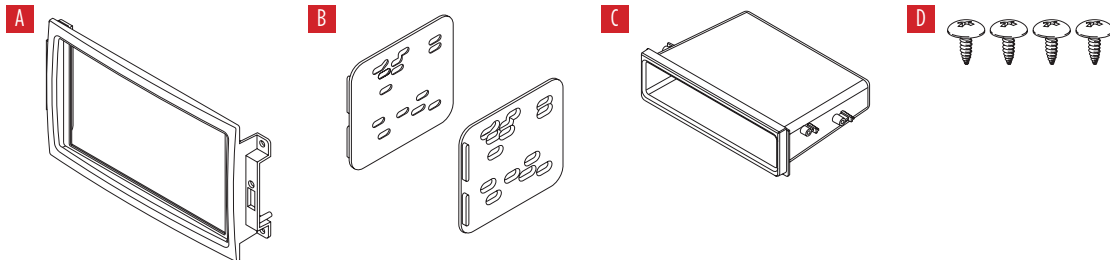

TABLE OF CONTENTS

See page 2

WIRING & ANTENNA CONNECTIONS (sold separately)

Wiring Harness: CHT0-01 - Models w/factory amp
XSVI-6502-NAV - Models w/o factory amp
Antenna Adapter: 40-CR10

TOOLS REQUIRED

- Panel removal tool
- Phillips screwdriver
- Socket wrench

CAUTION! All accessories, switches, climate controls panels, and especially air bag indicator lights must be connected before cycling the ignition. Also, do not remove the factory radio with the key in the on position, or while the vehicle is running.

APPLICATIONS

Chrysler

300	2005-2007
Aspen	2007

Dodge

Caliber	2007-2008
Charger	2006-2007
Durango	2004-2007
Magnum	2005-2007
Ram 1500	2006-2008
Ram 2500/3500	2006-2009

Jeep

Compass	2007-2008
Commander	2006-2007
Grand Cherokee	2005-2007
Patriot	2007-2008

TABLE OF CONTENTS

Dash Disassembly

Chrysler

- 300 2005-2007	4
- Aspen 2007	3

Dodge

- Dodge Caliber 2007-2008	7
- Charger 2006-2007	3

- Durango 2005-2007	3
- Magnum 2005-2007	3

- Ram 1500 2006-2008, 2500/3500 (without center console) 2006-2009	4
--	---

- Ram 1500 2006-2008, 2500/3500 (with mini center console) 2006-2009	5
--	---

- Ram 1500 2006-2008, 2500/3500 (with full center console) 2006-2009	6
--	---

Jeep

- Commander 2006-2007	7
- Compass 2007-2008	7
- Grand Cherokee 2005-2007	7
- Patriot 2007-2008	7

Kit Assembly

- ISO DIN radio provision with pocket	8
- ISO DDIN radio provision	9

DASH DISASSEMBLY

Chrysler Aspen 2007

Dodge Durango 2004-2007

1. Remove (2) 7mm screws from the inside of the pocket facing upward. (Figure A)
2. Unclip and remove the entire trim panel surrounding the radio and climate controls. (Figure B)
3. Remove (4) 7mm screws securing radio to dash and remove radio. (Figure C)

Continue to Kit Assembly

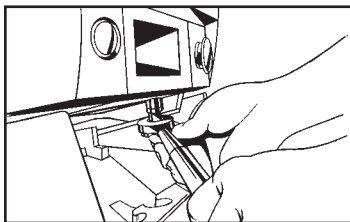

(Figure A)

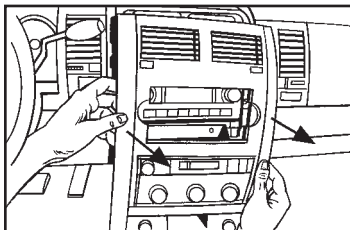

(Figure B)

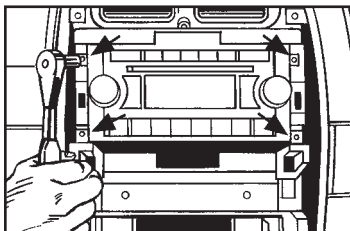

(Figure C)

Dodge Charger 2006-2007

Dodge Magnum 2005-2007

1. Unclip and remove entire panel surrounding radio and climate controls, including A/C vents. (Figure A)
2. Remove (4) 7mm screws securing radio to dash and remove radio. (Figure B)

Continue to Kit Assembly

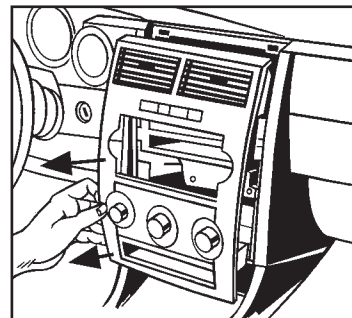

(Figure A)

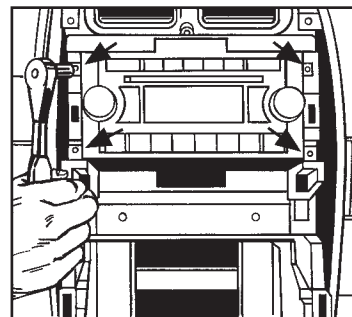

(Figure B)

DASH DISASSEMBLY

Chrysler 300 2005-2007

1. Unclip and remove entire panel surrounding radio and climate controls, including A/C vents and clock. (Figure A)
2. Remove (4) 7mm screws securing radio to dash and remove radio. (Figure B)

Continue to Kit Assembly

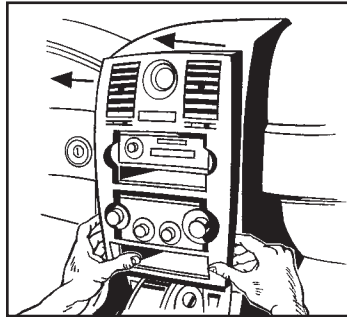

(Figure A)

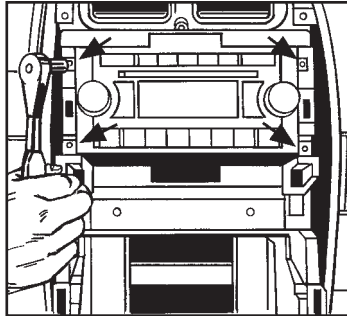

(Figure B)

Dodge Ram 1500 2006-2008

Dodge Ram 2500/3500 (w/o center console) 2006-2009

1. Open cup holder and remove (2) Phillips screws facing up on front edge of radio/ climate control panel. (Figure A)
2. Unclip and remove entire panel surrounding radio and climate controls, including A/C vents. (Figure B)
3. Remove (4) 7mm screws securing radio to dash and remove radio.

Continue to Kit Assembly

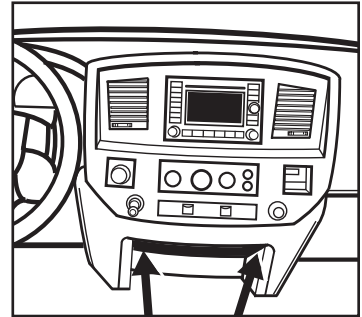

(Figure A)

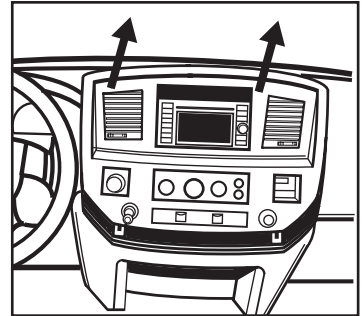

(Figure B)

DASH DISASSEMBLY

Dodge Ram 1500 2006-2008

Dodge Ram 2500/3500 (w/mini center console) 2006-2009

1. If vehicle has floor shifter, remove shifter knob.
2. Remove center console inserts, if present. (Figure A)
3. Remove screws securing the rear center console to the floor panel. Lift up on the rear center console to clear the gearshift lever, if present. (Figure B)
4. Remove screws securing the front center console to the floor panel. Unclip and remove the front center console. (Figure C)

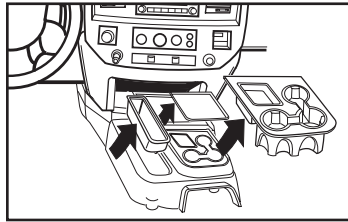

(Figure A)

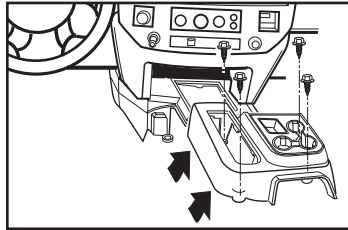

(Figure B)

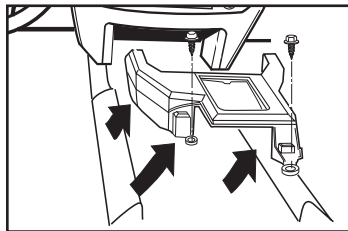

(Figure C)

5. Loosen (2) 8mm screws at bottom of dash. Unsnap lower panel.
6. Remove (2) Phillips screws facing up on front edge of radio/climate control panel. (Figure D)
7. Unclip and remove entire panel surrounding radio and climate controls, including A/C vents. (Figure E)
8. Remove (4) 7mm screws securing radio to dash and remove radio.

Continue to Kit Assembly

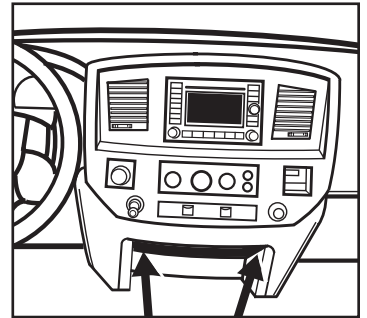

(Figure D)

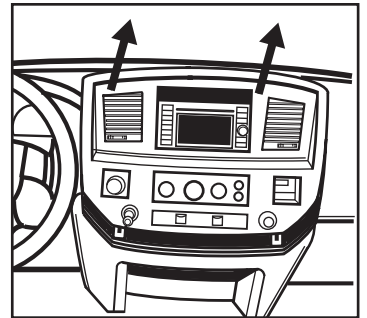

(Figure E)

DASH DISASSEMBLY

Dodge Ram 1500 2006-2008

Dodge Ram 2500/3500 (w/full center console) 2006-2009

1. If vehicle has floor shifter, remove shifter knob.
2. Unsnap and remove console front top cover (closest to the dash). (Figure A)
3. Remove (2) 8mm screws from under console cover (previously removed). Remove front section of console. (Figure B)
4. Loosen (2) 8mm screws at bottom of dash. Unsnap lower panel.

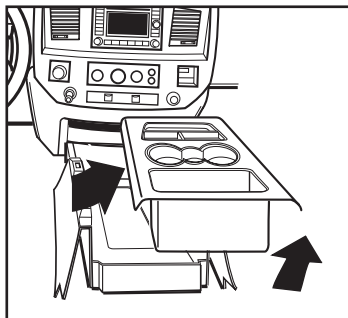

(Figure A)

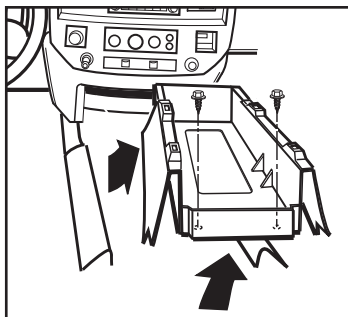

(Figure B)

5. Remove (2) Phillips screws facing up on front edge of radio/climate control panel. (Figure C)
6. Unclip and remove entire panel surrounding radio and climate controls, including A/C vents. (Figure D)
7. Remove (4) 7mm screws securing radio to dash and remove radio.

Continue to Kit Assembly

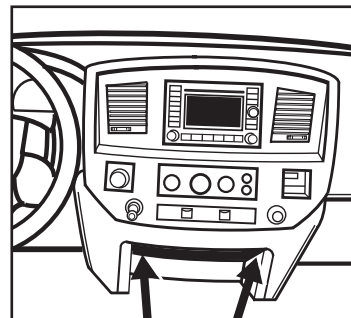

(Figure C)

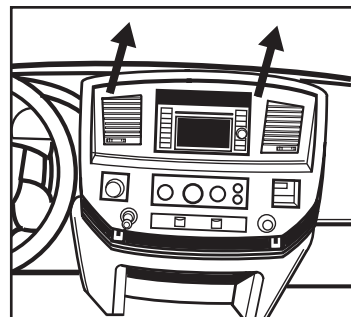

(Figure D)

DASH DISASSEMBLY

Jeep Grand Cherokee 2005-2007

1. Unsnap and remove panel from around radio including the vent on each side. (Figure A)
2. Remove (4) 7mm screws securing radio to dash and remove radio. (Figure B)

Continue to Kit Assembly

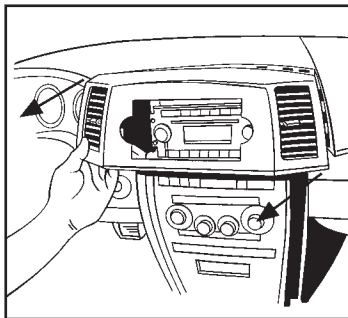

(Figure A)

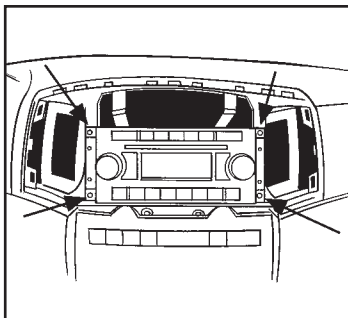

(Figure B)

Dodge Caliber, Jeep Compass, Jeep Patriot 2007-2011

1. Unsnap and move shifter trim to the side. (Figure A)
2. Unsnap and remove top center dash panel above A/C vents (Compass and Patriot only).
3. Unsnap center dash trim panel (do not remove until climate controls are removed). (Figure A)

4. Remove (4) Phillips screws holding climate control panel to backside of the center dash panel.
5. Remove (4) 7mm screws securing radio. Unplug and remove radio.

Continue to Kit Assembly

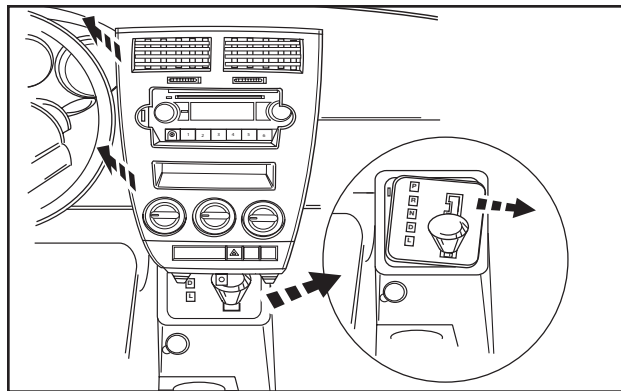

(Figure A)

KIT ASSEMBLY

ISO DIN radio provision with pocket

1. Attach the *radio brackets* to the *radio housing* by sliding the grooves in the brackets, into the housing. The following step will secure the brackets in place. (Figure A)
2. Attach the *pocket* to the *radio brackets* using the (4) #8 x 3/8" Phillips screws provided. (Figure B)
3. Remove the metal DIN sleeve and trim ring from the aftermarket radio.
4. Slide the radio into the bracket/pocket assembly, and then secure it using the screws supplied with the radio. (Figure C)

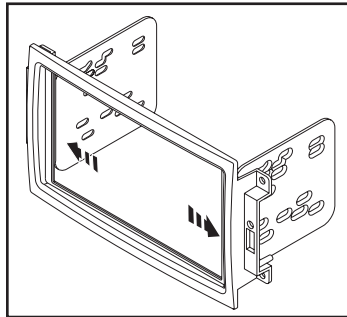

(Figure A)

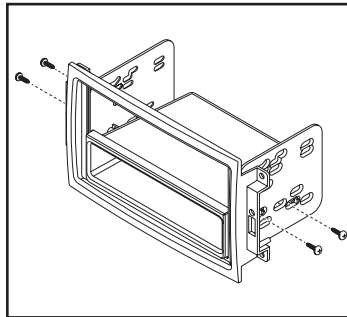

(Figure B)

5. Locate the factory wiring harness and antenna connector in the dash and complete all necessary connections to the radio. Metra recommends using the proper mating adapter from Metra and/or Axxess. Test the radio for proper operation.
6. Secure the radio assembly to the dash using the factory screws.
7. Reassemble the dash in reverse order of disassembly to complete the installation.

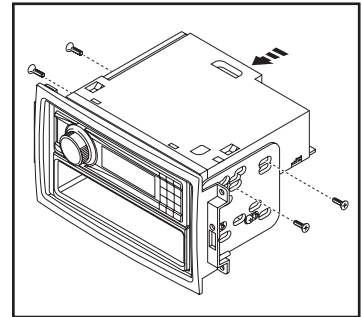

(Figure C)

KIT ASSEMBLY

ISO DDIN radio provision

1. Attach the *radio brackets* to the *radio housing* by sliding the grooves in the brackets, into the housing. The following step will secure the brackets in place. (Figure A)
2. Attach the *radio brackets* to the radio using the screws supplied with the radio. (Figure B)
3. Locate the factory wiring harness and antenna connector in the dash and complete all necessary connections to the radio. Metra recommends using the proper mating adapter from Metra and/or Axxess. Test the radio for proper operation.
4. Secure the radio assembly to the dash using the factory screws.
5. Reassemble the dash in reverse order of disassembly to complete the installation.

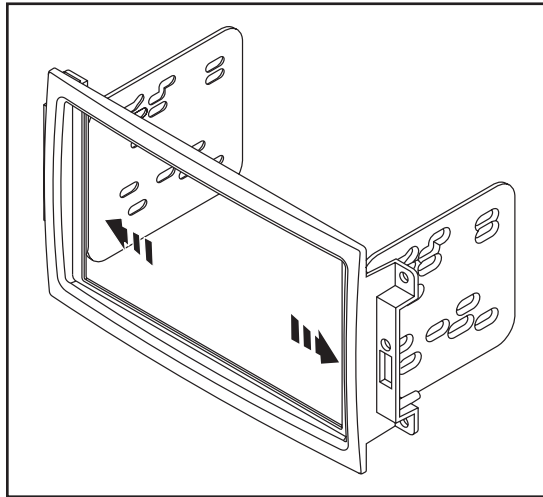

(Figure A)

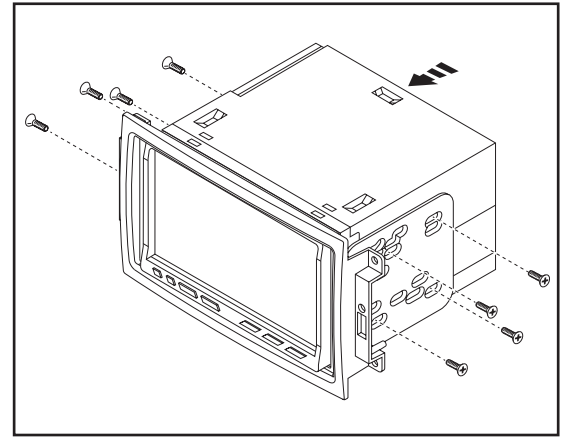

(Figure B)







99-6510
INSTALLATION INSTRUCTIONS



IMPORTANT

If you are having difficulties with the installation of this product, please call our Tech Support line at 1-800-253-TECH. Before doing so, look over the instructions a second time, and make sure the installation was performed exactly as the instructions are stated. Please have the vehicle apart and ready to perform troubleshooting steps before calling.



KNOWLEDGE IS POWER

Enhance your installation and fabrication skills by enrolling in the most recognized and respected mobile electronics school in our industry. Log onto www.installerinstitute.com or call 800-354-6782 for more information and take steps toward a better tomorrow.



**Metra recommends MECP
certified technicians**



Chrysler, Dodge, Jeep **Multikit** (con NAV) 2004-2009

CARACTERÍSTICAS DEL KIT

- Provisión de radio ISO DIN con cavidad
- Provisión de radio ISO DDIN
- Diseñado para vehículos con radios de navegación de fábrica

COMPONENTES DEL KIT

- A) Carcasa del radio • B) Soportes del radio • C) Cavidad • D) (4) Tornillos Phillips #8 de 3/8"

A

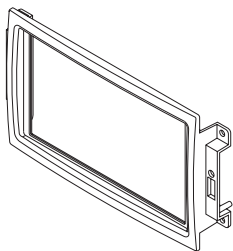

B

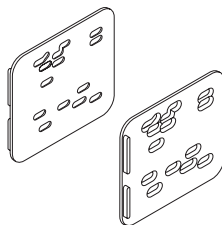

C

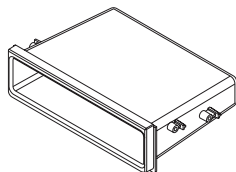

D



INDICE

Ver página 2

CABLEADO Y CONEXIONES DE ANTENA

(se venden por separado)

Arnés de cables: CHT0-01 - Para los modelos con un amplificador de fábrica

XSVI-6502-NAV - Para los modelos sin un amplificador de fábrica de fábrica

Adaptador de antena: 40-CR10

HERRAMIENTAS REQUERIDAS

- Herramienta para quitar paneles
- Destornillador Phillips • Llave del tubo

¡PRECAUCIÓN! Todos los accesorios, interruptores, paneles de controles de clima y especialmente las luces del indicador de las bolsas de aire deben estar conectados antes de encender el vehículo. Además, no quite el radio de fábrica con la llave en la posición de encendido ni con el vehículo funcionando.

APLICACIONES

Chrysler

300	2005-2007
Aspen	2007

Dodge

Caliber	2007-2008
Charger	2006-2007
Durango	2004-2007
Magnum	2005-2007
Ram 1500	2006-2008
Ram 2500/3500	2006-2009

Jeep

Compass	2007-2008
Commander	2006-2007
Grand Cherokee	2005-2007
Patriot	2007-2008

INDICE

Desmontaje del tablero

Chrysler

- 300 2005-2007	4
- Aspen 2007	3

Dodge

- Dodge Caliber 2007-2008	7
- Charger 2005-2007	3
- Durango 2005-2007	3
- Magnum 2005-2007	3
- Ram 1500 2006-2008, 2500/3500 (sin consola central) 2006-2009	4
- Ram 1500 2006-2008, 2500/3500 (con pequeño consola central) 2006-2009	5
- Ram 1500 2006-2008, 2500/3500 (con consola central completa) 2006-2009	6

Jeep

- Commander 2006-2007	7
- Compass 2007-2008	7
- Grand Cherokee 2005-2007	7
- Patriot 2007-2008	7

Ensamble del kit

- Provisión de radio ISO DIN con cavidad	8
- Provisión de radio ISO DDIN	9

DESMONTAJE DEL TABLERO

Chrysler Aspen 2007

Dodge Durango 2004-2007

1. Retire los (2) tornillos de 7 mm de la parte interior del bolsillo hacia arriba. (Figura A)
2. Suelte y retire todo el panel de la moldura que rodea el radio y los controles de clima. (Figura B)
3. Retire los (4) tornillos de 7 mm que sujetan el radio al tablero y retire el radio. (Figura C)

Continúe con el ensamble del kit

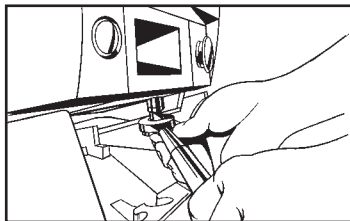

(Figura A)

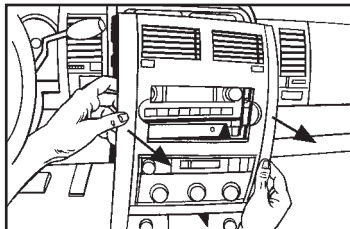

(Figura B)

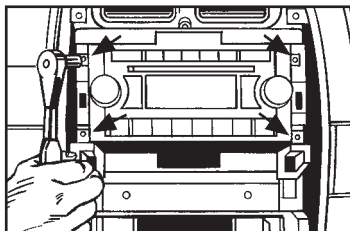

(Figura C)

Dodge Charger 2006-2007

Dodge Magnum 2005-2007

1. Suelte y retire todo el panel que rodea el radio y los controles del clima, incluyendo las rejillas del aire acondicionado. (Figura A)
2. Retire los (4) tornillos de 7 mm que sujetan el radio al tablero y retire el radio. (Figura B)

Continúe con el ensamble del kit

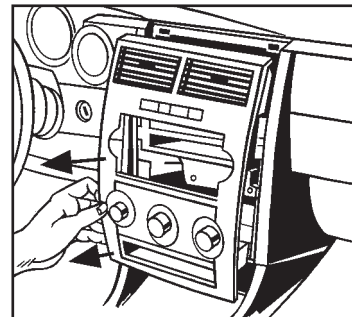

(Figura A)

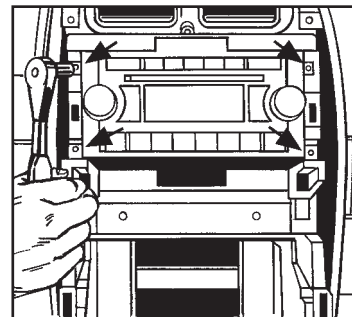

(Figura B)

DESMONTAJE DEL TABLERO

Chrysler 300 2005-2007

1. Suelte y retire todo el panel que rodea el radio y los controles del clima, incluyendo las rejillas del aire acondicionado y el reloj. (Figura A)
2. Retire los (4) tornillos de 7 mm que sujetan el radio al tablero y retire el radio. (Figura B)

Continúe con el ensamble del kit

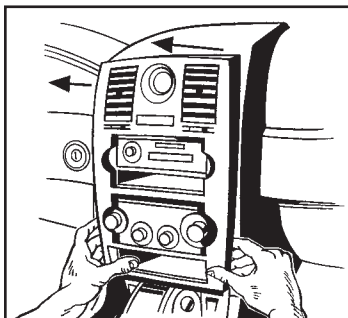

(Figura A)

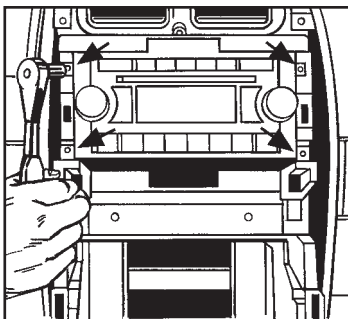

(Figura B)

Dodge Ram 1500 2006-2008

Dodge Ram 2500/3500 (sin consola central) 2006-2009

1. Abra el portavasos y retire los (2) tornillos Phillips que están hacia arriba en el borde frontal del panel del radio/control de clima. (Figura A)
2. Suelte y retire todo el panel que rodea el radio y los controles del clima, incluyendo las rejillas del aire acondicionado. (Figura B)
3. Retire los (4) tornillos de 7 mm que sujetan el radio al tablero y retire el radio.

Continúe con el ensamble del kit

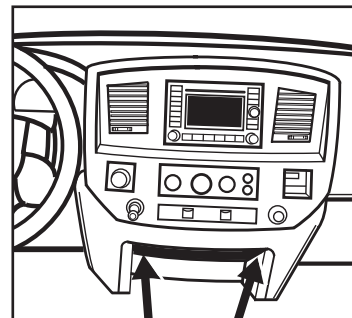

(Figura A)

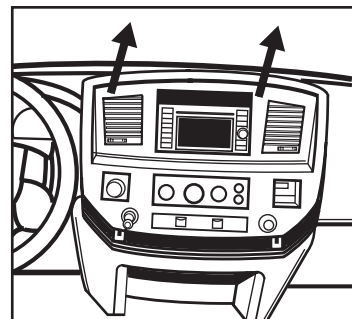

(Figura B)

DESMONTAJE DEL TABLERO

Dodge Ram 1500 2006-2008

Dodge Ram 2500/3500 (con pequeño consola central) 2006-2009

1. Si el vehículo tiene palanca de velocidades al piso, quite la perilla de la palanca.
2. Retire los insertos de la consola central, si los hay. (Figura A)
3. Retire los tornillos que sujetan la consola central trasera al panel del piso. Levante la consola central trasera para despejar el área de la palanca de velocidades, si la hay. (Figura B)
4. Retire los tornillos que sujetan la consola central delantera al panel del piso. Suelte y retire la consola central delantera. (Figura C)

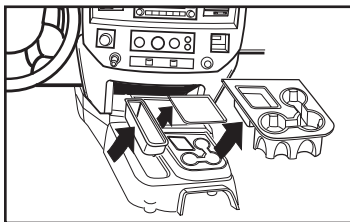

(Figura A)

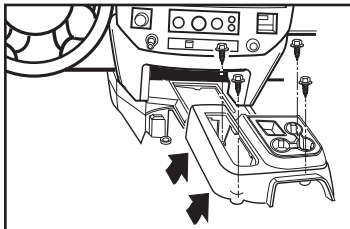

(Figura B)

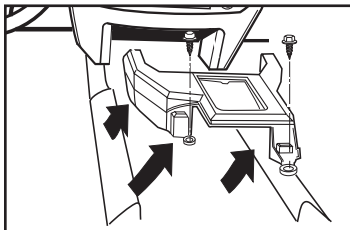

(Figura C)

5. Afloje los dos tornillos de 8 mm de la parte inferior del tablero. Suelte el panel inferior.
6. Retire los (2) tornillos Phillips que están hacia arriba en el borde frontal del panel del radio/control de clima. (Figura D)
7. Suelte y retire todo el panel que rodea el radio y los controles del clima, incluyendo las rejillas del aire acondicionado. (Figura E)
8. Retire los (4) tornillos de 7 mm que sujetan el radio al tablero y retire el radio.

Continúe con el ensamble del kit

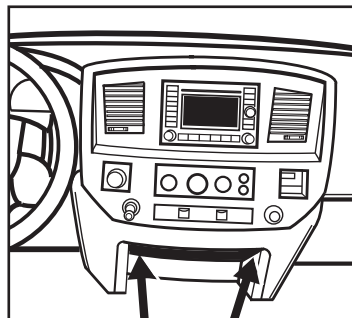

(Figura D)

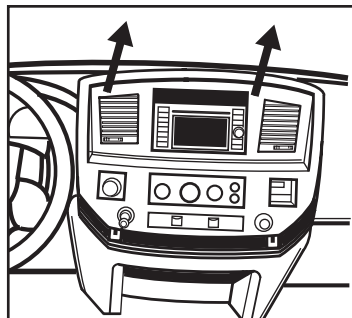

(Figura E)

DESMONTAJE DEL TABLERO

Dodge Ram 1500 2006-2008

Dodge Ram 2500/3500 (con consola central completa) 2006-2009

1. Si el vehículo tiene palanca de velocidades al piso, quite la perilla de la palanca.
2. Suelte y retire la cubierta superior del frente de la consola (más cercana al tablero). (Figura A)
3. Retire los dos tornillos de 8 mm de debajo de la cubierta de la consola (que se retiró anteriormente). Retire la sección frontal de la consola. (Figura B)

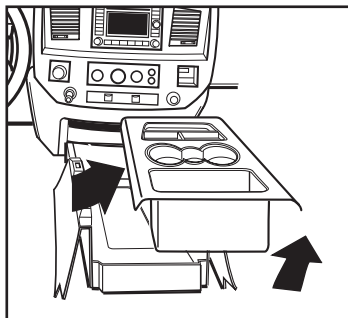

(Figura A)

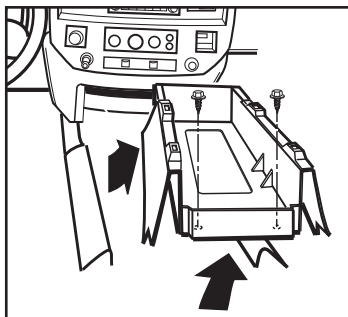

(Figura B)

4. Afloje los dos tornillos de 8 mm de la parte inferior del tablero. Suelte el panel inferior.
5. Retire los (2) tornillos Phillips que están hacia arriba en el borde frontal del panel del radio/control de clima. (Figura C)
6. Suelte y retire todo el panel que rodea el radio y los controles del clima, incluyendo las rejillas del aire acondicionado. (Figura D)
7. Retire los (4) tornillos de 7 mm que sujetan el radio al tablero y retire el radio.

Continúe con el ensamble del kit

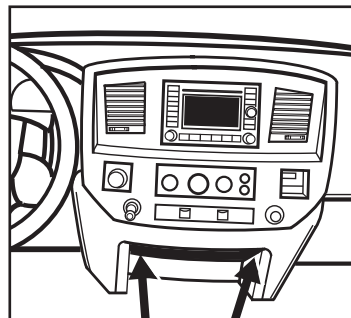

(Figura C)

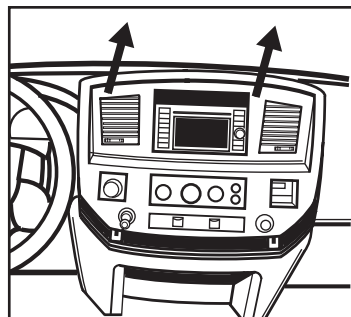

(Figura D)

DESMONTAJE DEL TABLERO

Jeep Grand Cherokee 2005-2007

1. Suelte y retire el panel de alrededor del radio, incluyendo la rejilla a cada lado. (Figura A)
2. Retire los (4) tornillos de 7 mm que sujetan el radio al tablero y retire el radio. (Figura B)

Continúe con el ensamble del kit

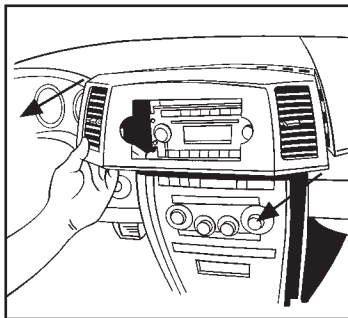

(Figura A)

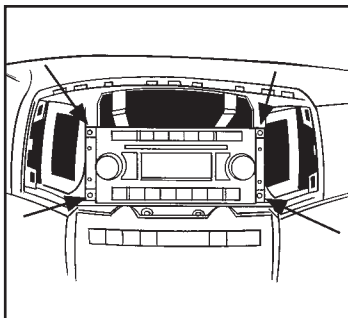

(Figura B)

Dodge Caliber, Jeep Compass, Jeep Patriot 2007-2011

1. Suelte y mueva la moldura de la palanca de velocidades a un lado. (Figura A)
2. Suelte a presión y retire el panel del tablero central superior arriba de las rejillas del aire acondicionado (solo Compass y Patriot).
3. Suelte el panel de la moldura del tablero central (no lo retire hasta que se hayan retirado los controles de clima). (Figura A)

4. Retire los (4) tornillos Phillips que sostienen el panel de control de clima a la parte posterior del panel del tablero central.
5. Retire los (4) tornillos de 7 mm que sostienen el radio. Desconecte y retire el radio.

Continúe con el ensamble del kit

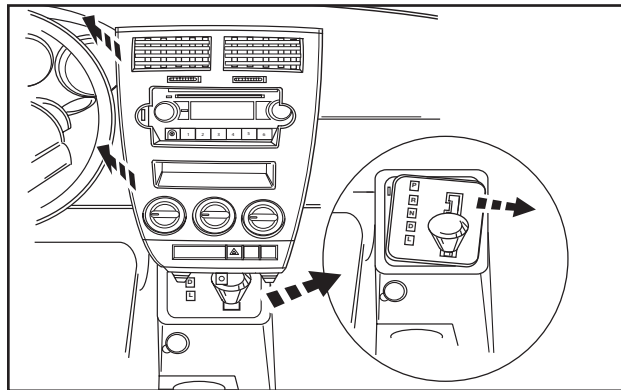

(Figura A)

ENSAMBLE DEL KIT

Provisión de radio ISO DIN con cavidad

1. Fije los *soportes de radio* a la carcasa de la radio deslizando las ranuras en los soportes, dentro de la carcasa. El siguiente paso asegurará los soportes en su lugar. (Figura A)
2. Sujete una *cavidad* a los *soportes del radio* usando los (4) tornillos #8 de 3/8" Phillips suministrados. (Figura B)
3. Quite la manga de metal DIN y el anillo de moldura del radio de mercado secundario.
4. Deslice el radio en el ensamblaje terminado y luego sujételo al ensamblaje con los tornillos suministrados con el radio. (Figura C)

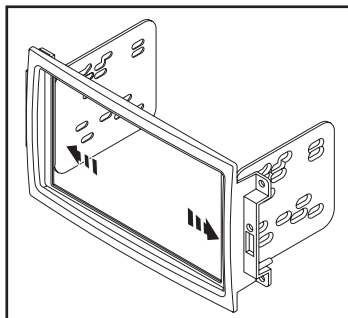

(Figura A)

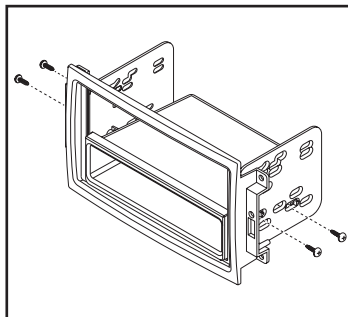

(Figura B)

5. Localice el arnés de cableado de fábrica y el conector de la antena en el tablero y realice todas las conexiones necesarias al radio. Metra recomienda el uso de un adaptador adecuado de acoplamiento de Metra. Pruebe el radio para verificar si funciona bien.
6. Sujete el ensamblaje completo al tablero utilizando los tornillos de fábrica.
7. Vuelva a ensamblar el tablero en el orden inverso al del desmontaje para completar la instalación.

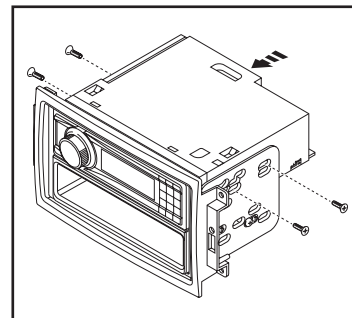

(Figura C)

ENSAMBLE DEL KIT

Provisión de radio ISO DDIN

1. Fije los *soportes de radio* a la carcasa de la radio deslizando las ranuras en los soportes, dentro de la carcasa. El siguiente paso asegurará los soportes en su lugar. (Figura A) (Figure A)
2. Conecte los *soportes de radio* a la radio con los tornillos suministrados con la radio. (Figura B)
3. Localice el arnés de cableado de fábrica y el conector de la antena en el tablero y realice todas las conexiones necesarias al radio. Metra recomienda el uso de un adaptador adecuado de acoplamiento de Metra. Pruebe el radio para verificar si funciona bien.
4. Sujete el ensamble completo al tablero utilizando los tornillos de fábrica.
5. Vuelva a ensamblar el tablero en el orden inverso al del desmontaje para completar la instalación.

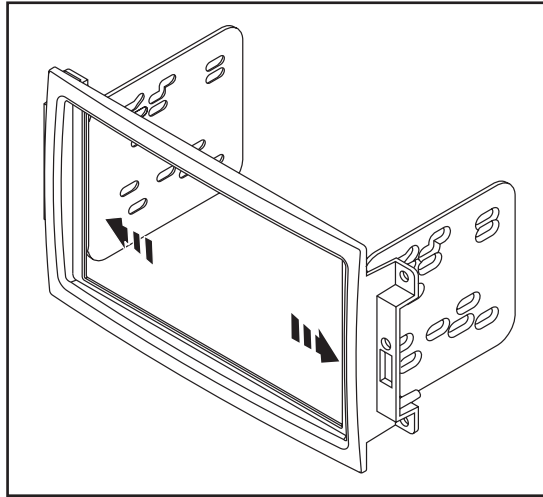

(Figura A)

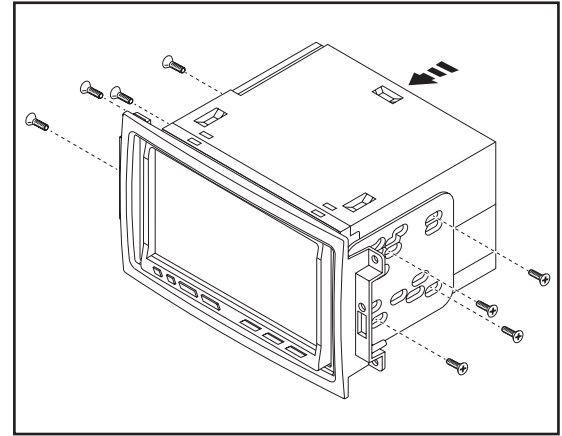

(Figura B)







99-6510

INSTRUCCIONES DE INSTALACIÓN



IMPORTANTE

Si tiene dificultades con la instalación de este producto, llame a nuestra línea de soporte técnico al 1-800-253-TECH. Antes de hacerlo, revise las instrucciones por segunda vez y asegúrese de que la instalación se haya realizado exactamente como se indica en las instrucciones. Por favor tenga el vehículo desarmado y listo para ejecutar los pasos de resolución de problemas antes de llamar.



EL CONOCIMIENTO ES PODER

Mejore sus habilidades de instalación y fabricación inscribiéndose en la escuela de dispositivos electrónicos móviles más reconocida y respetada de nuestra industria. Regístrese en www.installerinstitute.com o llame al 800-354-6782 para obtener más información y avance hacia un futuro mejor.



**Metra recomienda MECP
Técnicos certificados**