



INSTALLATION INSTRUCTIONS FOR PART 95-6511-17

APPLICATIONS

Chrysler

Aspen 2008-09/Sebring 2007-09
Town and Country 2008-09/300/300c 2008-09

Dodge

Avenger 2007-09/Caliber 2009/Challenger 2009
Charger 2008-09/Dakota 2008-09/Durango 2008-09
Grand Caravan 2008-09/Journey 2009*
Magnum 2008/ Nitro 2007-09/Ram 1500 2009

Jeep

Compass 2009/Commander 2008-09/Grand Cherokee 2008-09/Patriot 2009
Liberty 2008-09/Wrangler 2007-09*

**(Modifications to radio cavity required)*

Mitsubishi

Raider 2008

95-6511-17

KIT FEATURES

- Double DIN Radio Provision
- Stacked ISO Units Provision

KIT COMPONENTS

A) Double DIN Brackets/Trim Plate

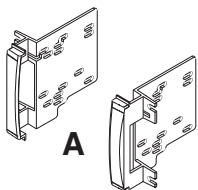

WIRING AND ANTENNA CONNECTIONS (Sold Separately)

Harness:

- XSVI-6522-NAV - Chrysler CAN rap harness 07-up
- CHT0-03 - Chrysler CAN amp harness 07-up

Antenna Adapter:

- 40-EU10 - European antenna adapter 02-up

TOOLS REQUIRED:

Small Flat Blade Screwdriver/ Panel Removal Tool

- Phillips Screwdriver • Socket Set



1-800-221-0932



www.metraonline.com

© COPYRIGHT 2017 METRA ELECTRONICS CORPORATION

TABLE OF CONTENTS

Dash Disassembly

- Chrysler Aspen 2008-2009/Dodge Durango 2008-2009 1
- Chrysler Sebring 2007-2009 2
- Chrysler Town and Country 2008-2009 3,4
- Chrysler 300/300C 2008-2009 5
- Dodge Avenger 2007-2009 6
- Dodge Caliber 2009 12
- Dodge Challenger 2009 12
- Dodge Dakota 2008-2009 7
- Dodge Grand Caravan 2008-2009 3,4
- Dodge Magnum/Charger 2008 5
- Dodge Nitro 2007-2009/Liberty 2008-2009 8
- Dodge Journey 2009 (Modifications to radio cavity required) 9
- Dodge Ram 1500 2009 13,14
- Jeep Commander/Grand Cherokee 2008-2009 10
- Jeep Compass 2009 12
- Jeep Patriot 2009 12
- Jeep Wrangler 2007-2009 (Modifications to radio cavity required) ... 11
- Mitsubishi Raider 2008 7

Kit Assembly

- Double DIN Radio Provision 15
- Stacked ISO Units Provision 15

Final Assembly 16

**Note:*

Refer also to the instructions included with the aftermarket radio.



KNOWLEDGE IS POWER

Enhance your installation and fabrication skills by enrolling in the most recognized and respected mobile electronics school in our industry. Log onto www.installerinstitute.com or call 800-354-6782 for more information and take steps toward a better tomorrow.

CHRYSLER ASPEN 2008-2009
DODGE DURANGO 2008-2009

- 1** Disconnect the negative battery terminal to prevent an accidental short circuit.
- 2** Unsnap and remove storage cup holder assembly. (Figure A)
- 3** Remove (2) screws from bottom edge of center dash trim panel. Unsnap and remove the panel. (Figure B)
- 4** Remove (4) screws securing the radio. Unplug and remove radio. (Figure C)

Continue to kit assembly.

A

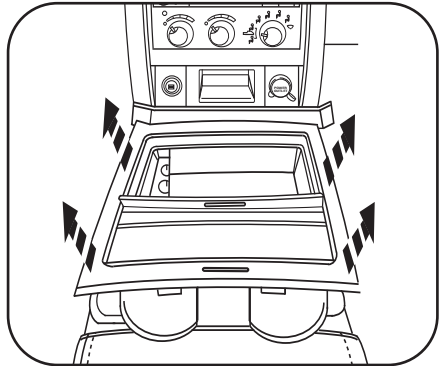

B

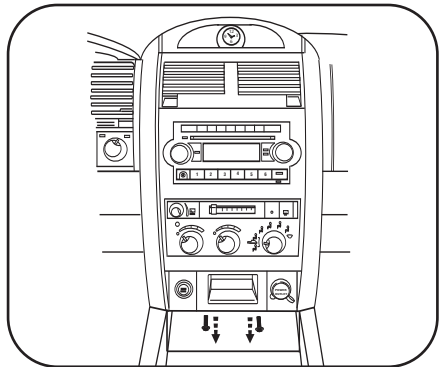

C

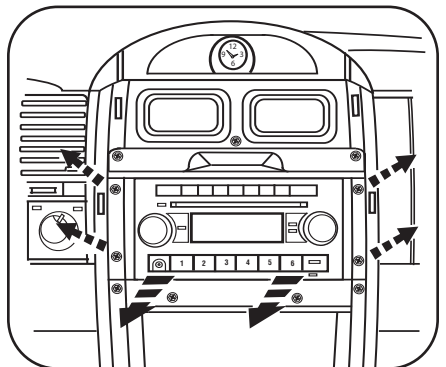

CHRYSLER SEBRING 2007-2009

- 1** Disconnect the negative battery terminal to prevent an accidental short circuit.
- 2** Unclip entire panel surrounding radio including a/c vents and clock. Unplug and remove panel. (Figure A)
- 3** Remove (4) 7MM screws securing radio. Unplug and remove radio. (Figure B)

Continue to kit assembly.

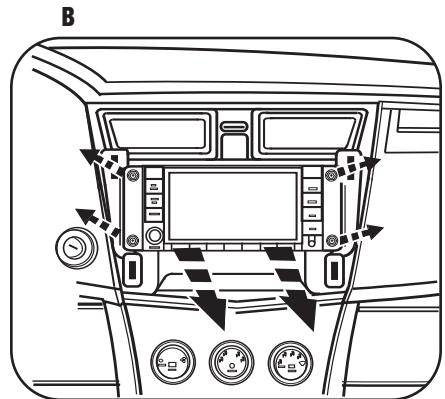
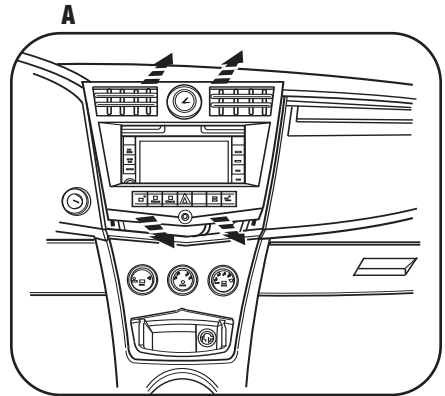

CHRYSLER TOWN AND COUNTRY 2008-2009
DODGE GRAND CARAVAN 2008-2009

- 1** Disconnect the negative battery terminal to prevent an accidental short circuit.
- 2** Remove (2) screw covers facing up above radio then remove the (2) Phillips screws exposed. (Figure A)
- 3** Lift up on panel above radio then remove (2) Phillips screws exposed at front edge of radio trim panel. (Figure B)
- 4** Remove (3) plastic push pins per side of bottom trim panel then slide panel toward rear of van to access (2) screws on bottom of radio trim panel. (Figure C)

Continued on page 3.

A

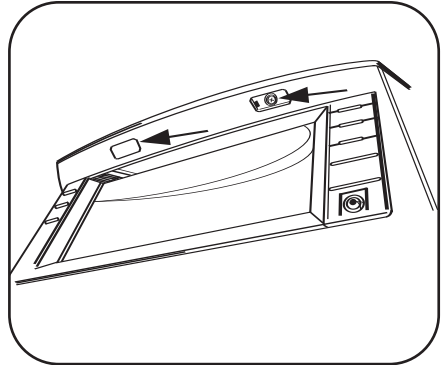

B

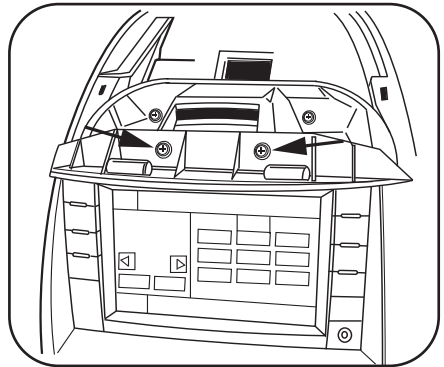

C

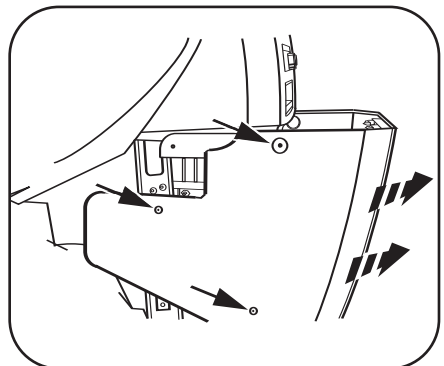

CHRYSLER TOWN AND COUNTRY 2008-2009
DODGE GRAND CARAVAN 2008-2009

- 5 Remove (2) Phillips screws exposed at bottom edge radio trim panel. (Figure D)
- 6 Unclip and remove entire panel surrounding radio including climate controls, vents and clock. (Figure E)
- 7 Remove (4) Phillips screws securing radio. (Figure F)

Continue to kit assembly.

D

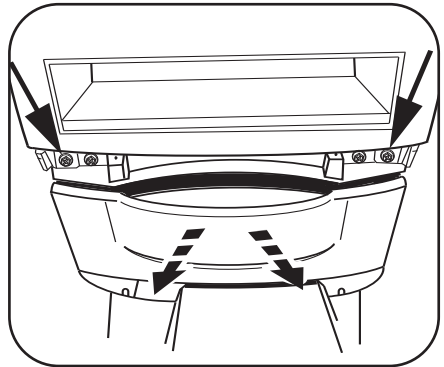

E

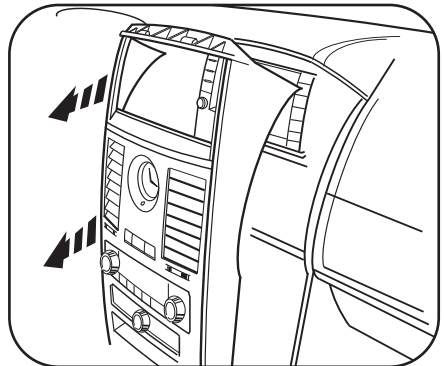

F

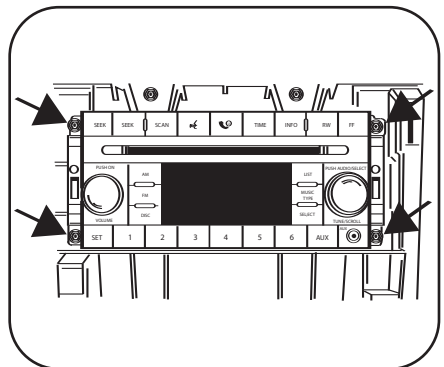

CHRYSLER 300/300C 2008-2009 **DODGE MAGNUM/CHARGER 2008**

- 1** Disconnect the negative battery terminal to prevent an accidental short circuit.
- 2** Unsnap and remove center dash trim panel. (Figure A)
- 3** Remove (4) screws securing the radio. Disconnect and remove the radio. (Figure B)

Continue to kit assembly.

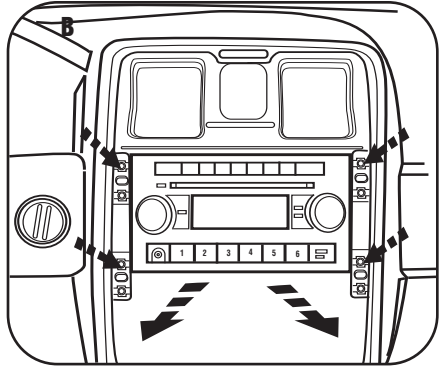
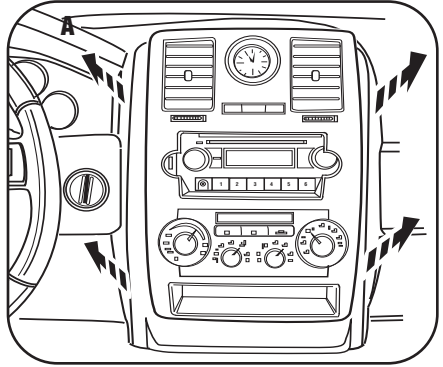

DODGE AVENGER 2007-2009

- 1** Disconnect the negative battery terminal to prevent an accidental short circuit.
- 2** Unclip and remove the center console trim panel. (Figure A)
- 3** Unclip the center dash trim panel. (Figure B)
- 4** Remove (4) screws securing the radio. Disconnect and remove the radio. (Figure C)
- 5** Remove (3) screws securing the radio rear support bracket and remove the bracket. (Figure D)

Continue to kit assembly.

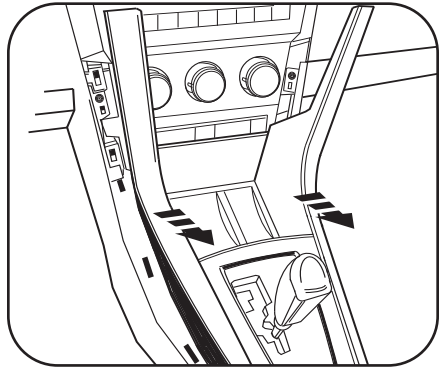
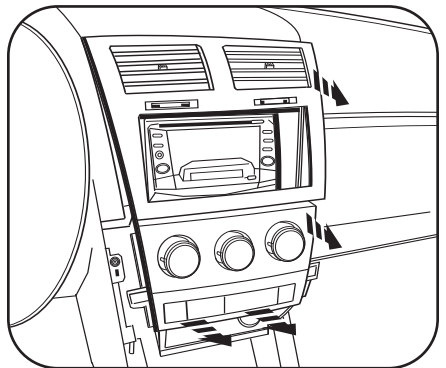
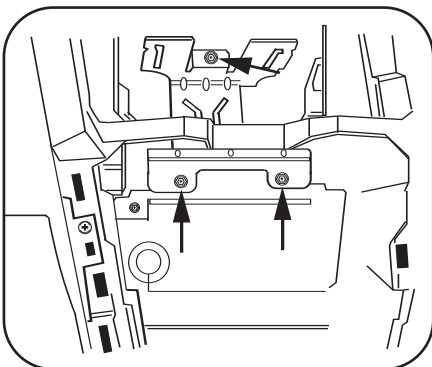
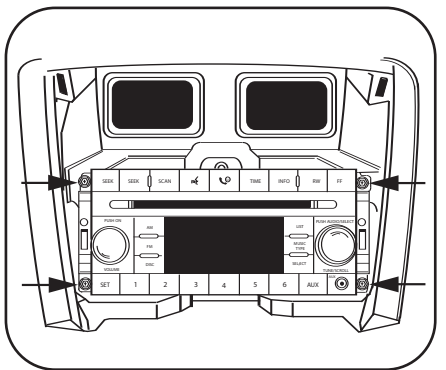
A

B

D

C

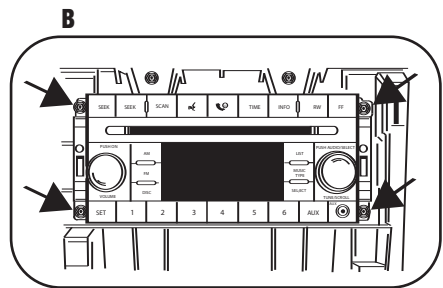
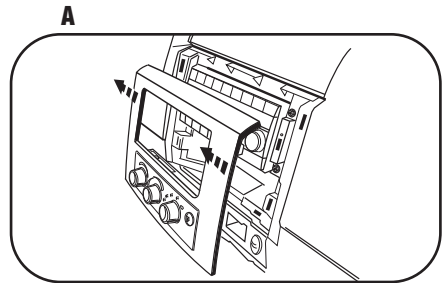
DODGE DAKOTA 2008-2009

- 1** Disconnect the negative battery terminal to prevent an accidental short circuit.
- 2** Unclip and remove the trim panel surrounding the radio. (Figure A)
- 3** Remove (4) Phillips screws securing the radio. (Figure B)

Continue to kit assembly.



MITSUBISHI RAIDER 2008

- 1** Disconnect the negative battery terminal to prevent an accidental short circuit.
- 2** Unsnap and remove center dash panel. (Figure A)
- 3** Remove (4) 7mm screws securing the radio. Unplug and remove radio.

Continue to kit assembly.

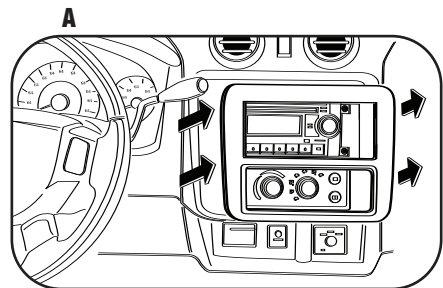

DODGE NITRO 2007-2009
JEEP LIBERTY 2008-2009

- 1** Disconnect the negative battery terminal to prevent an accidental short circuit.

- 2** Unclip entire panel surrounding radio and climate controls, including a/c vents. Unplug and remove panel. (Figure A)

- 3** Remove (4) 7MM screws securing radio. Unplug and remove radio. (Figure B)

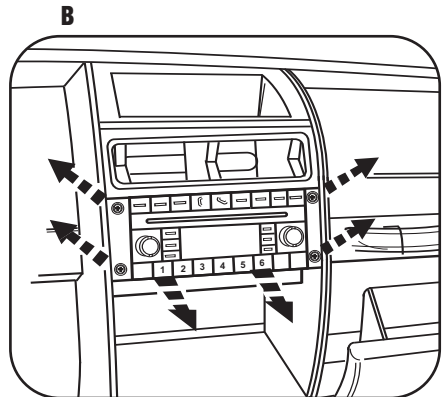
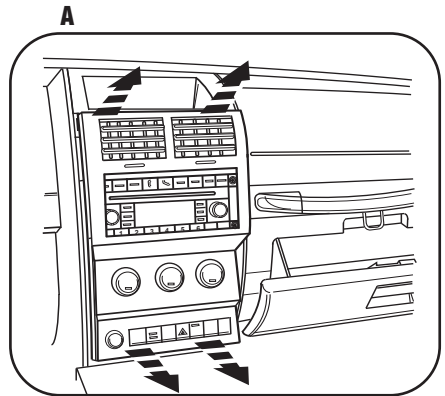

Continue to kit assembly.

DODGE JOURNEY 2009

- 1** Disconnect the negative battery terminal to prevent an accidental short circuit.
- 2** Unclip and remove the entire factory radio trim panel including the a/c controls. (Figure A)
TIP: *Open the compartment door at the top of the radio trim panel.*
- 3** Remove (4) 7MM screws securing radio to dash to remove. (Figure B)

NOTE: *The top of the metal bracket in the sub dash will need to be cut to allow for the clearance of the Double DIN radio's chassis. (Figure C)*

Continue to kit assembly.

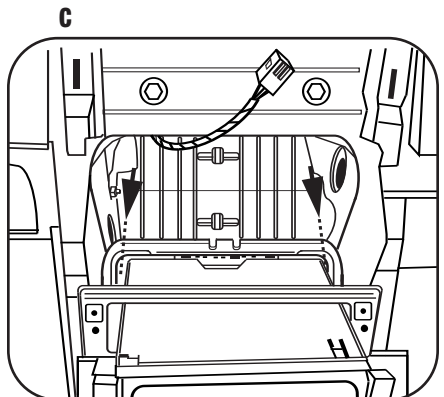
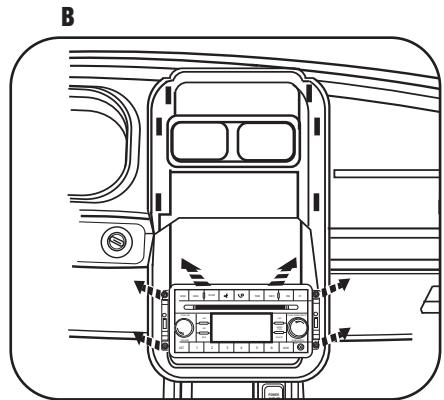
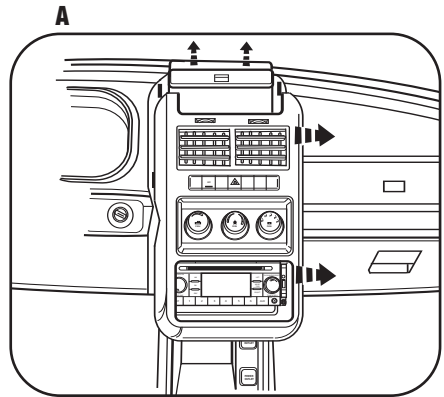

JEEP COMMANDER/GRAND CHEROKEE 2008-2009

- 1 Disconnect the negative battery terminal to prevent an accidental short circuit.
- 2 Unsnap and remove the small trim around the console shifter. (Figure A)
- 3 Unsnap and remove the larger trim around the console shifter. (Figure B)
- 4 Remove one Phillips screw from inside the small storage pocket in the lower dash, between the power outlets. (Figure C)
- 5 Unsnap and remove the dash panel from around the radio (including climate controls). (Figure D)
- 6 Remove (4) Phillips screws securing the radio. Unplug and remove radio.

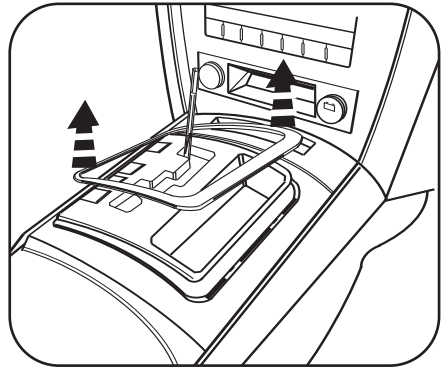
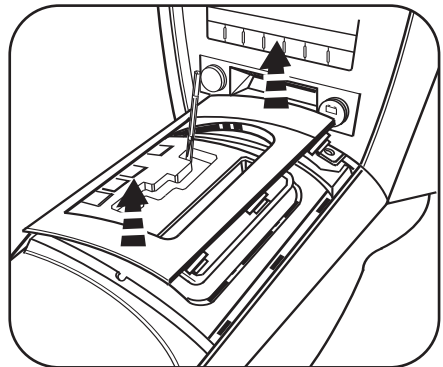
A

B

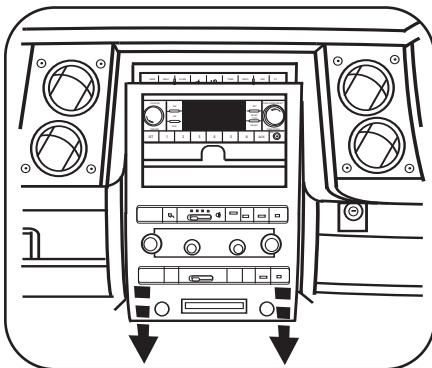
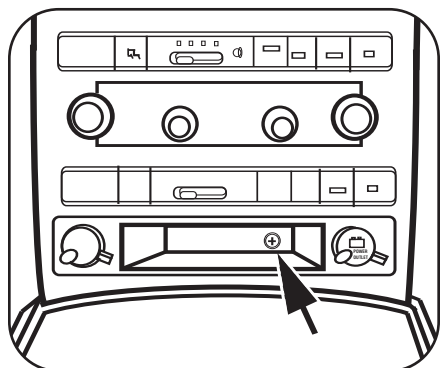
Continue to kit assembly.

D

C

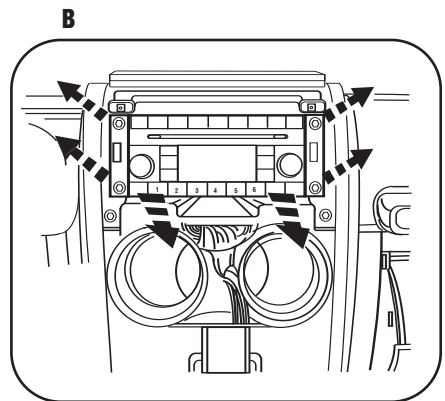
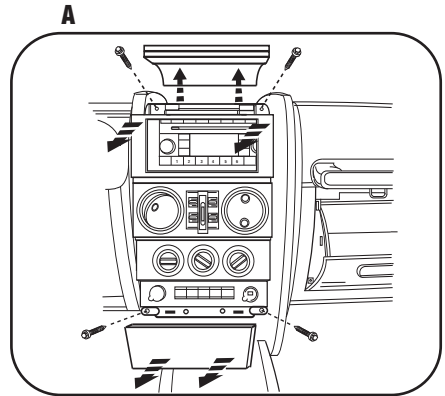
JEEP WRANGLER 2007-2009

- 1 Disconnect the negative battery terminal to prevent an accidental short circuit.
- 2 Unclip and remove the lower center trim below a/c controls. (Figure A)
- 3 Remove (2) Phillips screws exposed behind lower center panel. (Figure A)
- 4 Unclip and remove the upper center trim starting towards the rear of the panel. (Figure A)
- 5 Remove (2) Phillips screws exposed behind upper center panel. (Figure A)
- 6 Unclip and remove entire panel surrounding radio and climate controls, including a/c vents.
- 7 Remove (4) 7MM screws securing radio. Unplug and remove radio. (Figure B)



NOTE: *The top of the metal bracket in the sub dash will need to be cut to allow for the clearance of the Double DIN radio's chassis.*

Continue to kit assembly.

DODGE CALIBER 2009
DODGE CHALLENGER 2009
JEEP COMPASS 2009
JEEP PATRIOT 2009

- 1** Disconnect the negative battery terminal to prevent an accidental short circuit.
- 2** Unsnap and move shifter trim to the side. **(Figure A)**
- 3** Unsnap center dash trim panel (do not remove until climate controls are removed). **(Figure A)**
- 4** Remove (4) Phillips screws holding climate control panel to backside of the center dash panel.
- 5** Remove (4) 7MM screws securing radio. Unplug and remove radio.
- 6** The metal bracket in the sub-dash will need to be removed for the aftermarket Double DIN radio's depth.

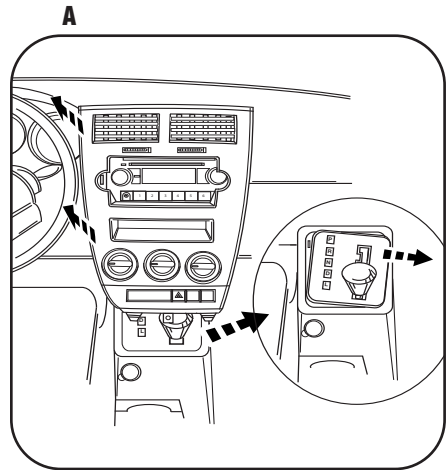

Continue to kit assembly.

DODGE RAM 1500 2009

- 1** Disconnect the negative battery terminal to prevent an accidental short circuit.
- 2** Remove (1) T25 Torx screw in the compartment next to the cup holders. (**Figure A**)
- 3** Remove (2) Phillips screws in the pocket below the climate control in the front of the center console. (**Figure B**)
- 4** Remove (2) 9/32" screws in the cup holders. (**Figure C**)
- 5** Push down on the collar below the shifter then pull the shifter straight up to remove. (**Figure D**)
- 6** Unclip and remove the top of the center console including the cup holders. (**Figure E**)

Continued on page 14.

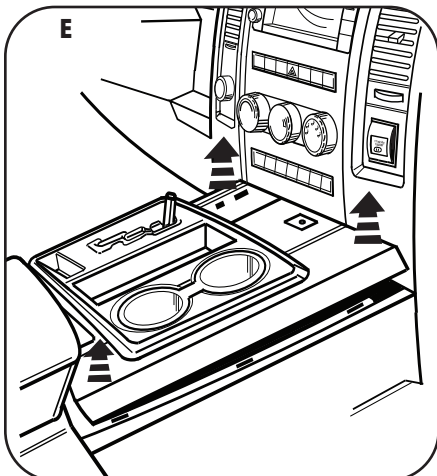
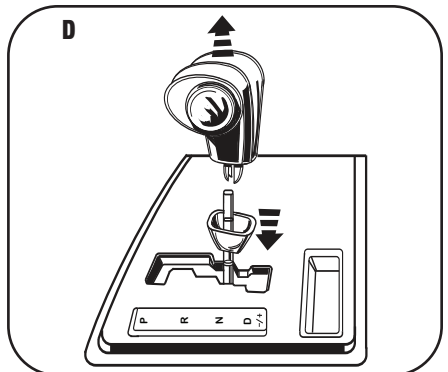
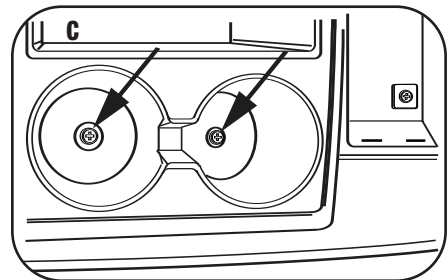
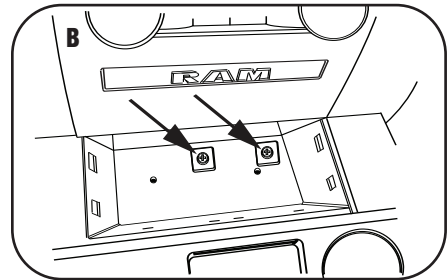
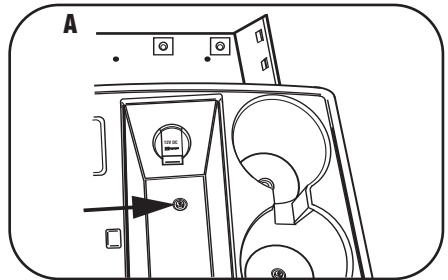

DODGE RAM 1500 2009

- 7** Unclip and remove the trim panel from the accessory socket on the radio trim panel, then remove (1) T25 Torx screw. **(Figure F)**
- 8** Remove (2) T25 Torx screws from the top of the radio trim panel. **(Figure G)**
- 9** Unclip and remove the entire radio trim panel including the climate controls. **(Figure H)**
- 10** Remove (4) 9/32" screws securing the radio. **(Figure I)**

Continue to kit assembly.

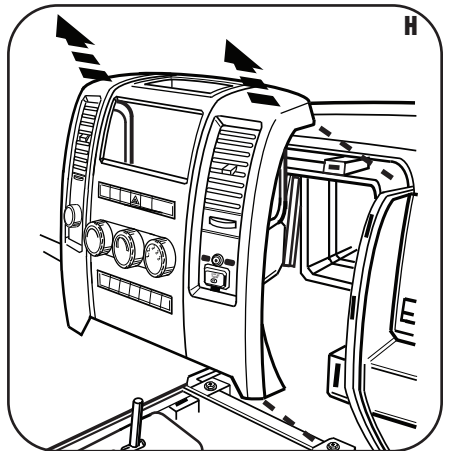
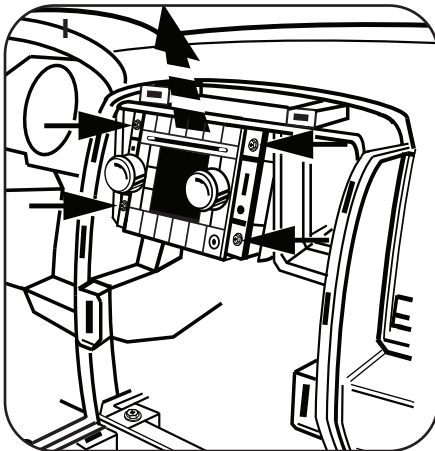
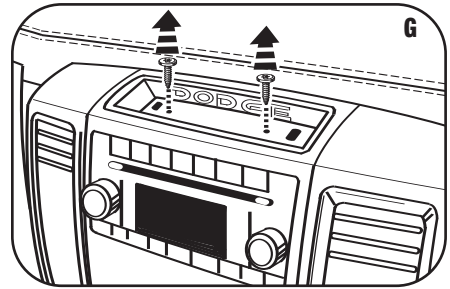
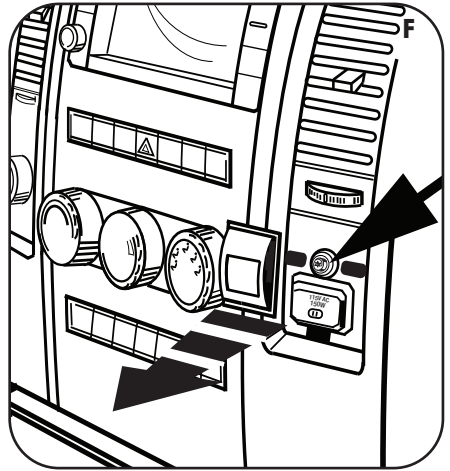

DOUBLE DIN RADIO PROVISION

**Note: Refer also to the instructions included with the aftermarket radio.*

- 1 Attach the Double DIN brackets/trim plates to the Double DIN Radio using the screws supplied with the Radio. (Figure A)

Continue to final assembly.

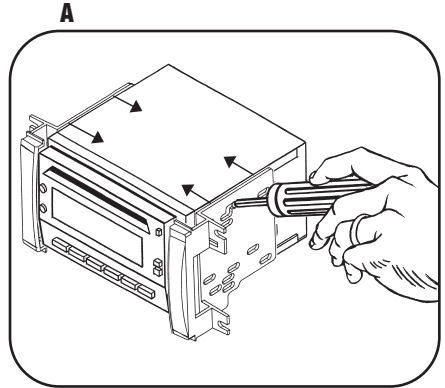

STACKED ISO UNITS PROVISION

**Note: Refer also to the instructions included with the aftermarket radio.*

- 1 Attach the Double DIN brackets/trim plates to the stacked ISO units using the screws supplied with the units. (Figure A)

Continue to final assembly.

